



### PRODUCT FEATURES:

- Retains factory features in select GM LAN 11 Bit vehicles while functioning with an aftermarket radio.
- Pre-programmed to retain factory Steering Wheel Controls.
- Supports Bose, non-Bose and Y-91 audio systems.
- Retains chime functions.
- Retains front and rear parking sensors.
- EIA color coded wiring for easy installation.

### NOTES:

1. **DOES NOT** support ONSTAR.

### PARTS INCLUDED:



GM-51 Module



GM-2A Harness



GM-2B Harness



SWC Cables



Antenna Adaptor



Dash Kit

### INSTALLATION DIAGRAM:

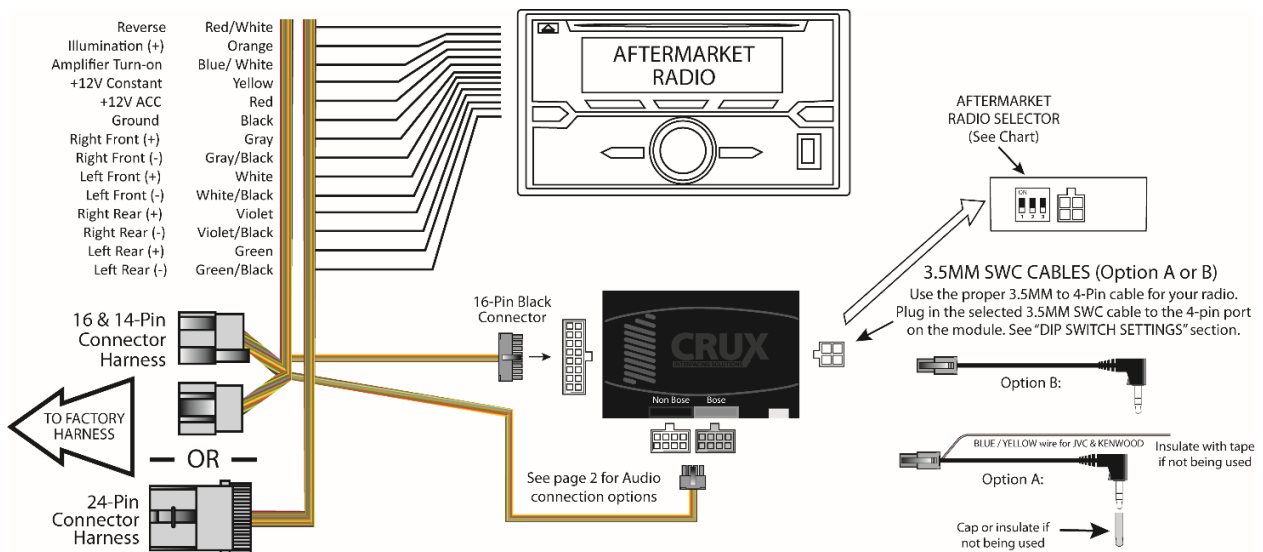



**DIP SWITCH SETTINGS:**

**SETTING THE AFTERMARKET RADIO BRAND**

With the key in the off position, set the DIP switches to the corresponding radio listed below.

RADIO BRAND:	DIP#:	1	2	3
Atoto, Dual, Fahrenheit, Jensen		OFF	ON	ON
Pioneer, Power Acoustik, Soundstream		OFF	ON	ON
Blaupunkt, Most off-brand Radio		OFF	ON	ON
Alpine		OFF	OFF	OFF
Clarion		ON	ON	OFF
Kenwood		ON	ON	ON
JVC		ON	OFF	ON
Boss, Old Sony		ON	OFF	OFF
New Sony		OFF	ON	OFF

SWC MODULE  
DIP SWITCH



**NOTE:** For Atoto, Blaupunkt, Dual, Fahrenheit, Power Acoustik, Soundstream, and most off-brand radios, check the aftermarket radio’s manual to see if the SWC buttons need to be programmed.

**3.5MM SWC CABLE**

Use the proper 3.5 to 4 pin SWC cable for the aftermarket radio being used:

**OPTION A** is used for ALPINE, CLARION, (JVC and KENWOOD units will use the Blue/Yellow wire).

**OPTION B** is used for ATOTO, BOSS, DUAL, FAHRENHEIT, JENSEN, POWER ACOUSTIK, PIONEER, SONY, SOUND STREAM and most OFF-BRAND headunits.

**NOTE:** Cap or insulate the 3.5mm plug or Blue/Yellow wire if not being used.

**SELECTING THE AUDIO SYSTEM:**

If the vehicle is equipped with a Bose system, the GM-51 has a built-in Bose adaptor that allows the proper audio input gain from the aftermarket radio to the Bose amplifier. To use this feature, plug in the male 8-pin connector on the harness to the GRAY female 8-pin connector on the GM-51 module. The module is also labeled “Bose” and “Non Bose” to avoid confusion. (see picture below)

If the vehicle is NOT equipped with a Bose system, plug in the male 8-pin connector to the BLACK female 8-pin on the GM-51 module.





### CHIME VOLUME ADJUSTMENT:

The GM-51 module has a potentiometer to adjust the chime volume. It is set at half way by default. To adjust the volume, simply use a suitable screw driver and turn the potentiometer clockwise to increase the volume and counter-clockwise to decrease the volume.

Chime  
Volume  
Adjustment



### DASH KIT INSTALLATION:

A double DIN radio replacement dash kit is included in the kit to make the installation quick and easy. You have the option of installing a Double DIN or two Single DIN radios. The DKGM-51 kit includes:



### INSTALLATION:

#### Before installation:

1. Locate the main trim ring.
2. Locate the left and right mounting brackets.
3. Slide the appropriate mounting bracket into the trim ring, aligning the holes in the trim ring to the clips on the bracket.  
(See Diagram A on page 4)
4. For two Single DIN radio installation, slide the stacked ISO DIN unit into the trim ring bracket assembly and secure the unit to the kit using the screws supplied with the radio. (See Diagram B on page 4)



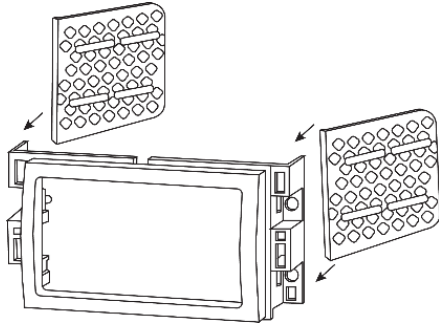

Diagram A

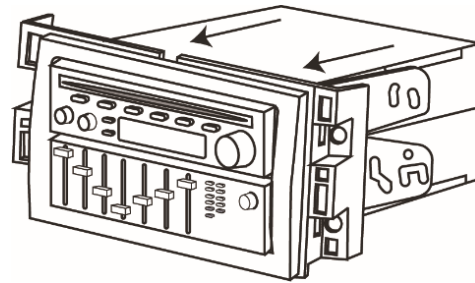

Diagram B

**VEHICLE APPLICATIONS:**

**16 and 14 PIN CONNECTORS**

**CHEVROLET**

2007-2010 Cobalt  
2006-2011 HHR  
2008-2012 Malibu

**PONTIAC**

2007-2010 G5  
2006-2010 Solstice

**SATURN**

2007-2010 Aura  
2007 Ion  
2007-2009 Sky

**24 PIN CONNECTOR**

**CHEVROLET**

2005-2006 Cobalt  
2004-2007 Malibu

**PONTIAC**

2005-2009 G6

