

**PRODUCT FEATURES:**

- Retains factory features in Select Mazda vehicles while functioning with an aftermarket radio.
- Pre-programmed to retain factory Steering Wheel Controls.
- EIA color coded wiring for easy installation.

**NOTES:**

1. Does not retain factory information display.
2. Does not support Digital Bose<sup>®</sup> System.
3. Does not retain A/C control feature (CAN-bus vehicles)
4. Does not retain Rear Seat Entertainment.
5. Does not retain clock setting.

**PARTS INCLUDED:**



SWRMZ-64C MODULE



SWRMZ-64C HARNESS

**INSTALLATION DIAGRAM:**

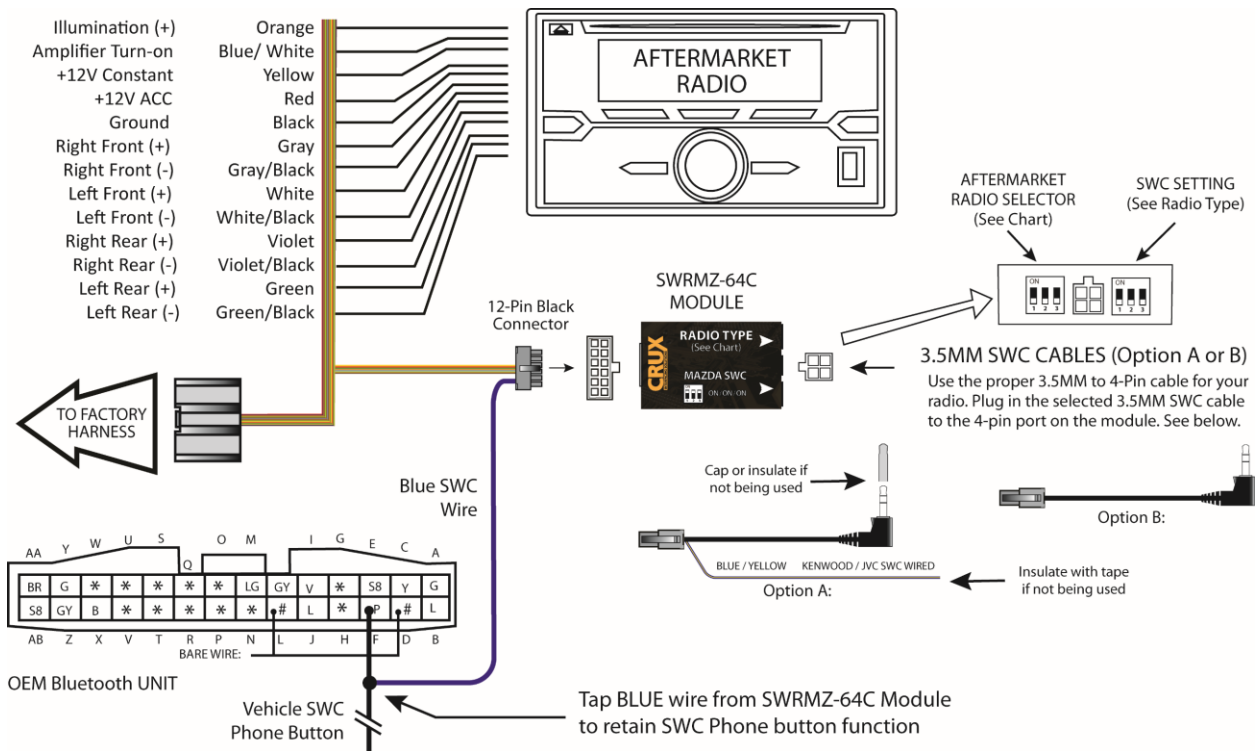

**DIP SWITCH SETTINGS:**

**SETTING THE AFTERMARKET RADIO BRAND**

This step is done on the Analog SWC Module. With the key in the off position, set the DIP switches to the corresponding radio listed below.

RADIO BRAND:	DIP:	1	2	3
Fahrenheit, Jensen, Pioneer		OFF	ON	ON
Power Acoustik, Sound Stream		OFF	ON	ON
Alpine		OFF	OFF	OFF
Clarion		ON	ON	OFF
Kenwood		ON	ON	ON
JVC		ON	OFF	ON
Sony, Boss		ON	OFF	OFF

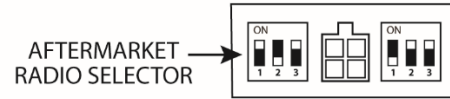

**4-PIN SWC CABLE**

The Analog SWC Module allows for both types of connections:

- OPTION A** is used for ALPINE, CLARION, (JVC and KENWOOD units will use the BLUE/YELLOW wire)
- OPTION B** is used for BOSS, DUAL, FAHRENHEIT, JENSEN, PIONEER, POWER ACOUSTIK, SONY & SOUND STREAM units.

*NOTE: Cap or insulate the 3.5mm plug or Blue/Yellow wire if not being used.*

**SETTING THE MAZDA SWC**

MAZDA SWC	DIP:	1	2	3
		ON	ON	ON

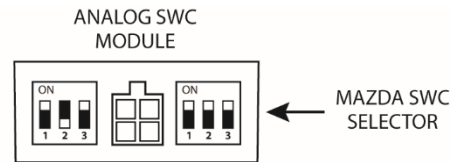

**VEHICLE APPLICATIONS:**

**MAZDA**

2013 - 2014	CX-5	2004 - 2011	RX-8
2007 - 2011	CX-7	2007 - 2011	Speed3
2007 - 2012	CX-9	2006 - 2007	Speed6
2011 - 2012	Mazda2	2006 - 2011	MX-5 Miata
2004 - 2015	Mazda3	2002 - 2006	MPV
2006 - 2014	Mazda5		
2003 - 2014	Mazda6		

